



VALLI S.r.l. - via Selva 12-14 - 47122 FORLÌ (FC) - ITALY
Ph: +39.0543.975311 - Fax: +39.0543.981400 - info@valli-italy.com - www.valli-italy.com

Instruction manual User's and maintenance

Model: Scraper

*Translation of original instructions
EU Directive 2006/42/EC*

This publication cancel and replace all previous editions and revisions.

We reserve the right to make changes without notice.

Edizione: 09/2024

Rev. A.03

1.3. Specifications

1.3.1. General technical data

The machine is presented in a modular configuration and can work from a few meters to the entire length of the system where it is installed (up to 150 meters).

Speed 12 m/min

Noise level: Machine noise is less than $Leq \leq 70$ dB (A)

Vibration: The machine does not transmit vibrations

Gas and radiation emissions: The machine does not emit harmful gases and/or radiation

Electromagnetic emissions: Electromagnetic emissions comply with the current state of the art of the art.

Gear motor mounted on the drive unit; it is dedicated to the movement of the scraper.

There is also an idler part consisting of a pulley mounted on bearings.

MOTOR

POT. (kW)	VOLTAGE (V)	STAGES	CYCLES (Hz)
2,2	230/400	3	50
3	230/400	3	50
3.60	208	3	60-CSA
3.60	230	3	60-UL
3.60	480	3	60-UL

GEARBOX

DESCRIPTION	REDUCTION(s)
CMM110 i:60+TOR18N25R4A110	60

1.3.2. Scheme of operation

The chain is wound on the gear wheel of the tow and then connected to the cable that is wrapped by the idler pulley, thus creating a closed loop allows the movement of the material coming from the system, continuously.

In the intermediate part between drive and idler are placed scrapers,

The material arriving by gravity from the plant, is deposited on the pavement and is conveyed to the manure pit .

On the drive side is installed the gear motor that drives the belt.

In the referral there is a system of cleaning the pulley from manure, pens and other elements that could lead to accumulations of material with consequent malfunction of the system.

The adjustment of the belt draft is possible, through two threaded bars connected in a closed loop to the system. Acting on the nuts by means of a key performs the draft of the system;

the alignment is guaranteed by the track on the tow and by the pipe installed under the crossbar of the systems.

Adjustment is possible in all plans of the system.



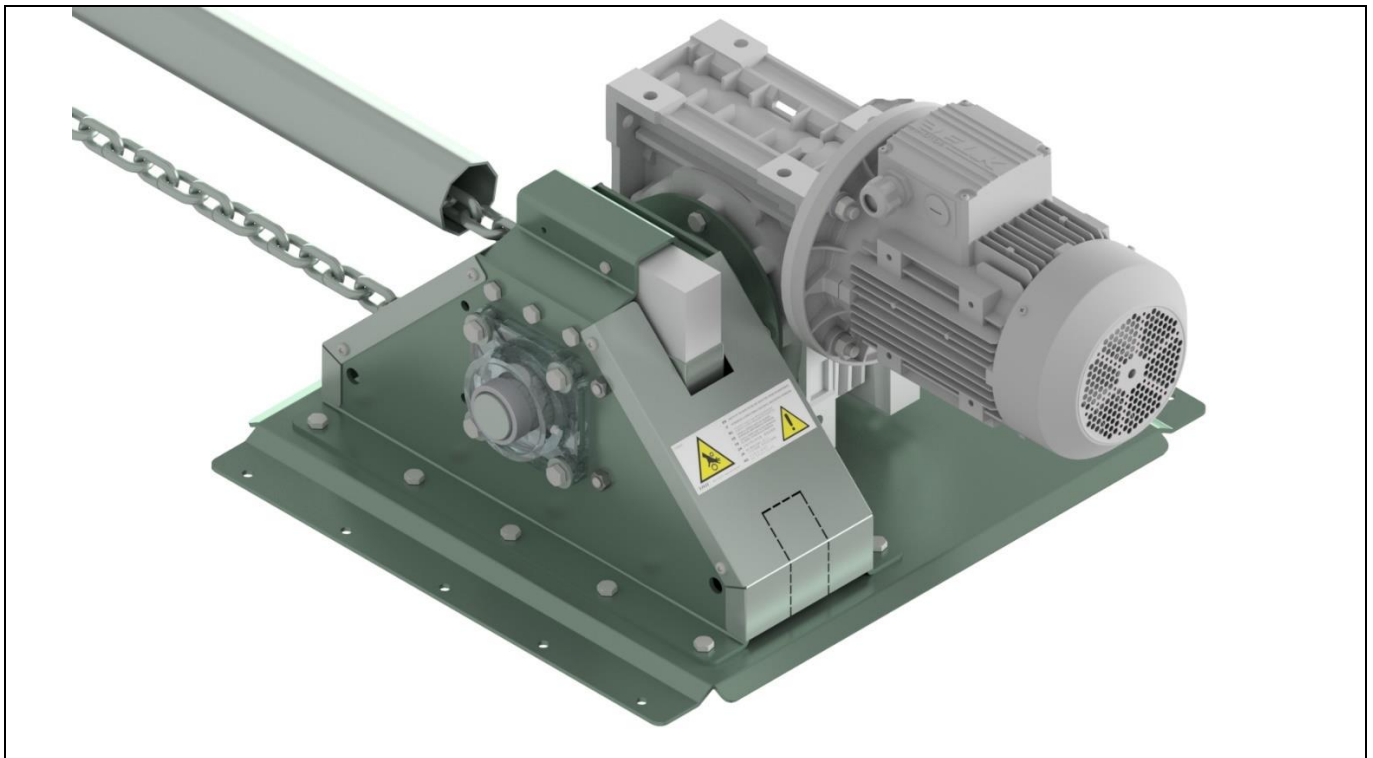

DRIVE

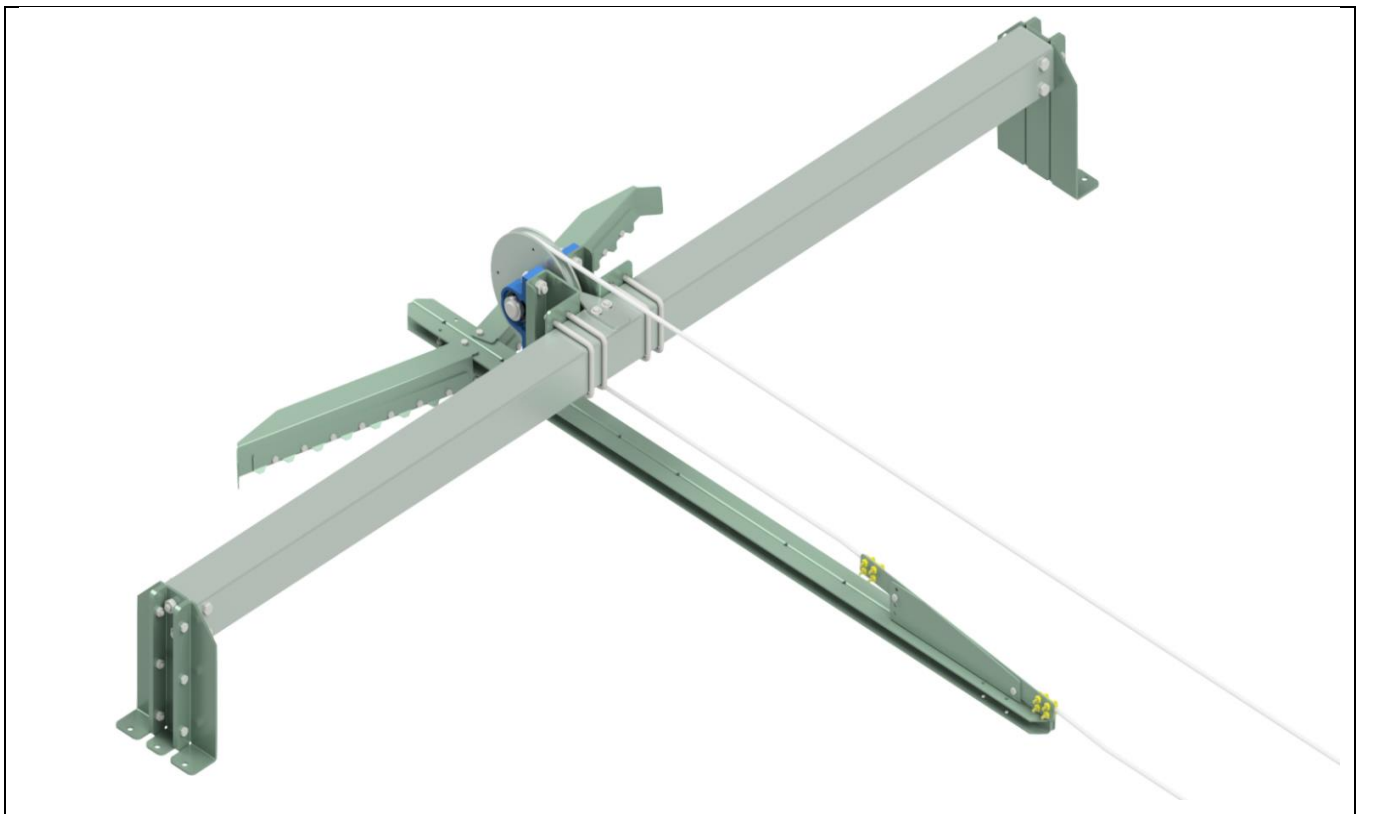

IDLER

1.3.3. Dimensions

In relation to the number of floors in simultaneous collection and the width of the egg belt leaving the elevator, different configurations of width, height and depth are available for the pollen conveyor belt

The machine provides a modular installation with the following configurations:

Available widths: 1400 mm AC (X)

Crossbar widths: 2100 MM AC (X1)

Development in maximum height 1 meter (Y)

Maximum machine length 150 m AC (Z)

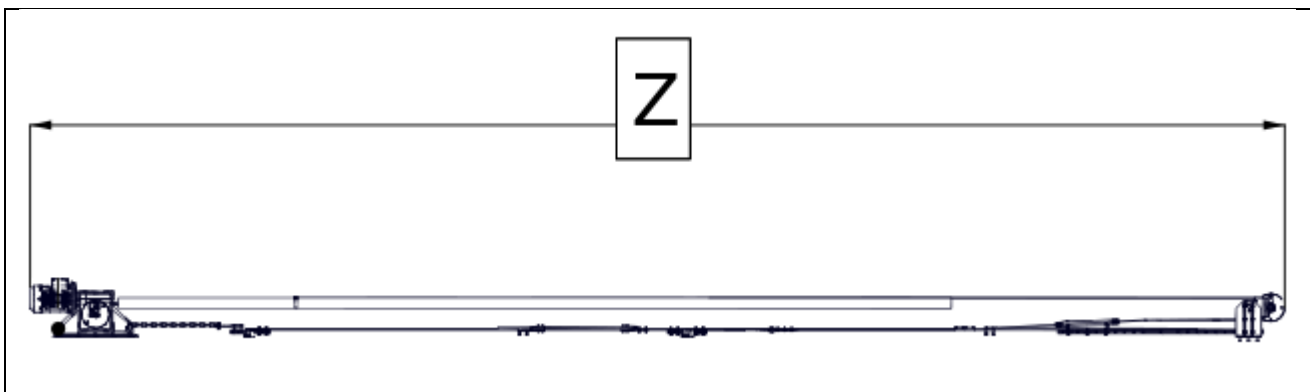
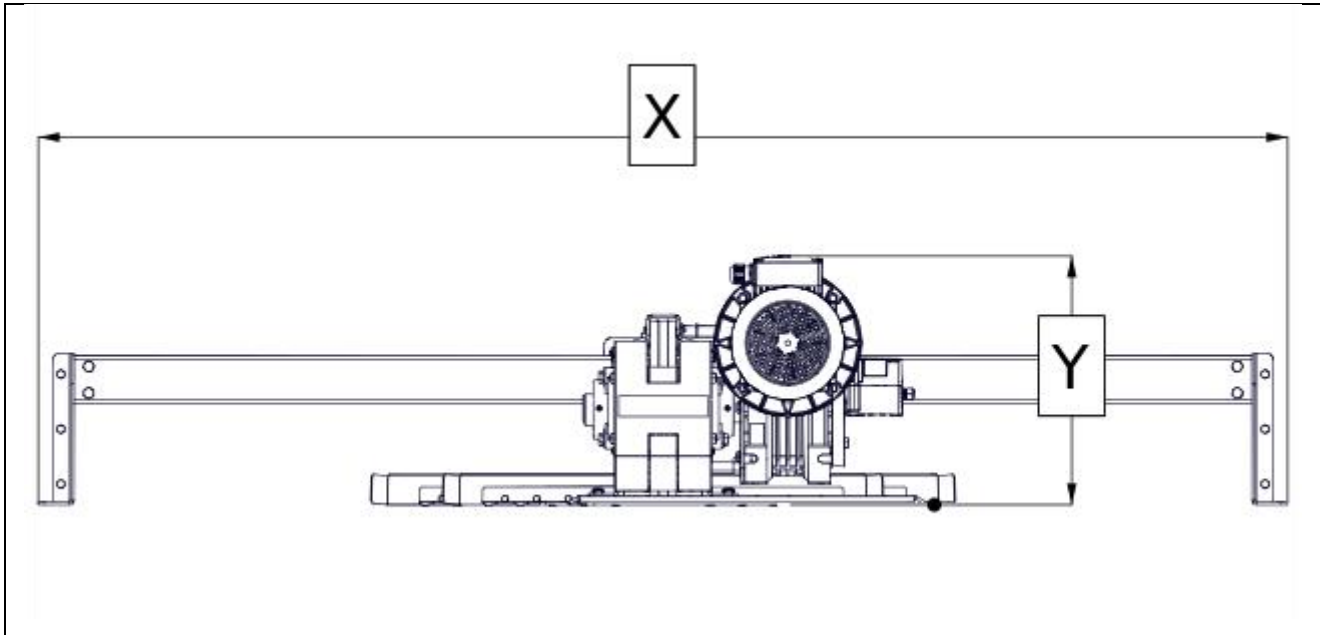

3.2.1. Floor

The machine must be installed inside an industrial building with a solid and leveled floor to support the weight of the machine, not on an inclined plane.

Make sure that the machine is perfectly resting on the floor.

Make sure that the flooring can withstand the weight of the machine and the space is suitable for the installation of the same.

FLOOR SURFACE STATUS: The floor of the reinforced concrete shed(s) for equipment housing, must meet the conditions

of flatness and horizontality. The flatness must comply with the provisions of the UNI 11146: 2005 standard summarized in the table below:

TOLERANCE ON FLATNESS: Deviation of concavity or convexity with respect to the nominal plane determined by the ruler used for the measurement

DISTANCE BETWEEN TWO CONTROL POINTS	1 m	2 m	4 m
TOLERANCE	± 4 mm	± 5 mm	± 6 mm

The horizontality tolerance in both directions, longitudinal and transverse, must meet the following condition: $\leq 1.5\text{‰}$



IN THE AREA WHERE FLOOR CONVEYOR IS INSTALLED CARRY OUT A POLISHING OF THE CONCRETE (KEEP THE FLOOR SMOOTH)



IT IS FORBIDDEN TO INSTALL THE MACHINE ON A BUMPY SURFACE

3.2.2. Lighting

The machine must be installed inside an illuminated industrial building at a point where the lighting is sufficient to ensure the vision of each part of the machine.

The lighting system, by the customer, must comply with the laws in force in the country where the machine is installed and must in any case guarantee good visibility at every point, not create reflections dangerous, allow the clear reading of the control panel, as well as the identification of emergency buttons, and do not interfere with any equipment installed on board the machine.

The day/night lighting of the plant is important for the safety and the quality of work; the working area must be illuminated effectively: it must not be too dark or with glare phenomena.

See the requirements of the UNI EN 12464-1 standard Light and lighting - Workplace lighting - Part 1: Indoor workplaces.

the limit is imposed by animal welfare during maintenance or inspection of the area concerned; we recommend a minimum illuminance to ensure the correct perception of the symbols and markings (minimum 200 lux).

3.2.3. Machine Assembly



If you assemble a "set of machines" for the study of the interference and connection of the various units, please refer to the general system diagram

Machine in modular configuration

Instructions for consulting and searching for details with YYXXXXX coding (two letters followed by n.5 X):

- obtain or print the packing list in pdf format
- open the packing list file
- perform the search for the desired detail through the description of the table
- obtain all the parts before assembling the machine

3.2.3.1 Overall

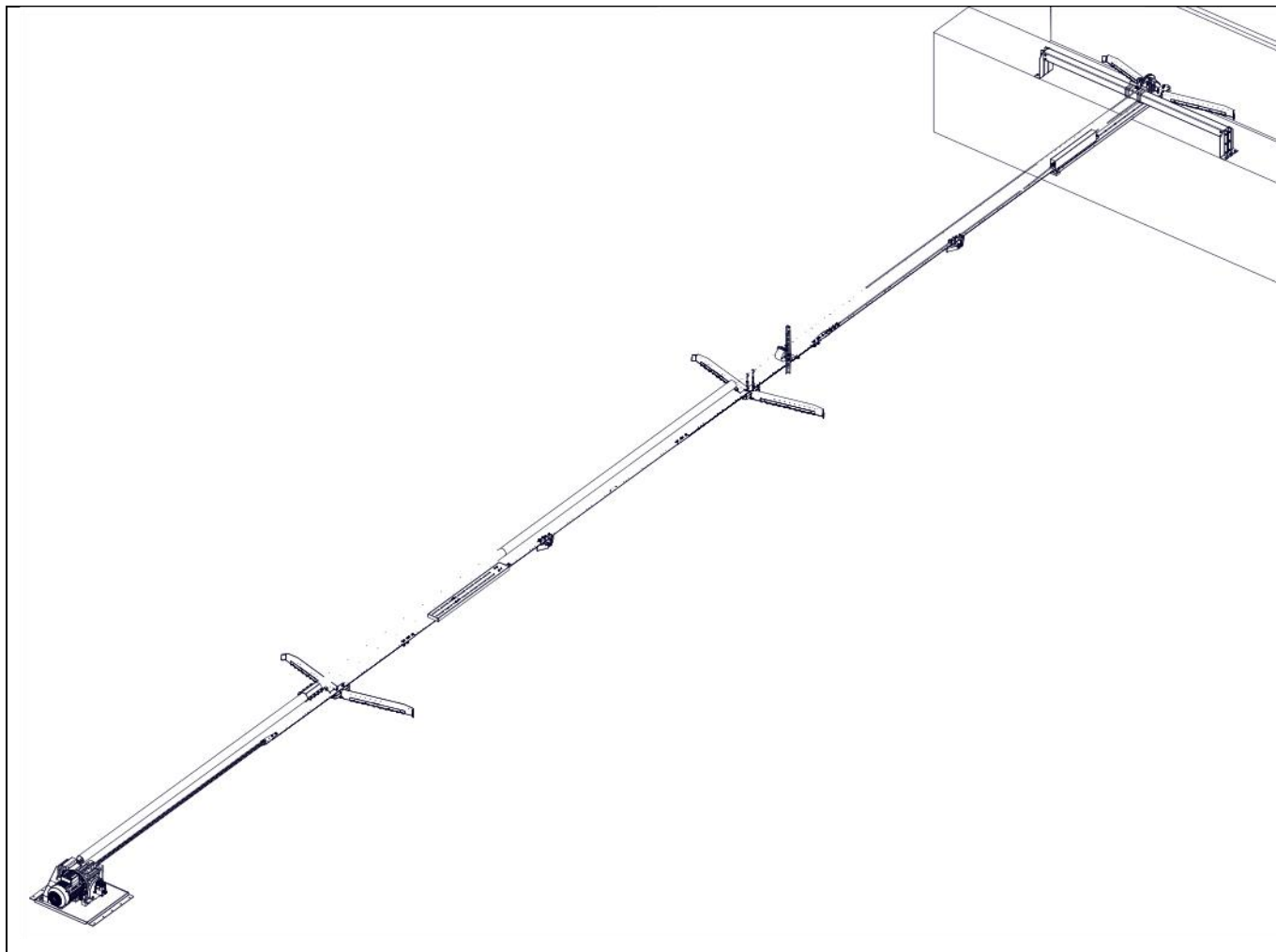

3.2.3.2 Drive mounting

**MOUNTING A DRIVE PER ROW AND FLOOR**

PLACE THE DRIVE NEAR THE FIRST DIVIDER OF THE SYSTEM. PAY ATTENTION TO THE IDLER MANURE BELT OF THE FIRST FLOOR.

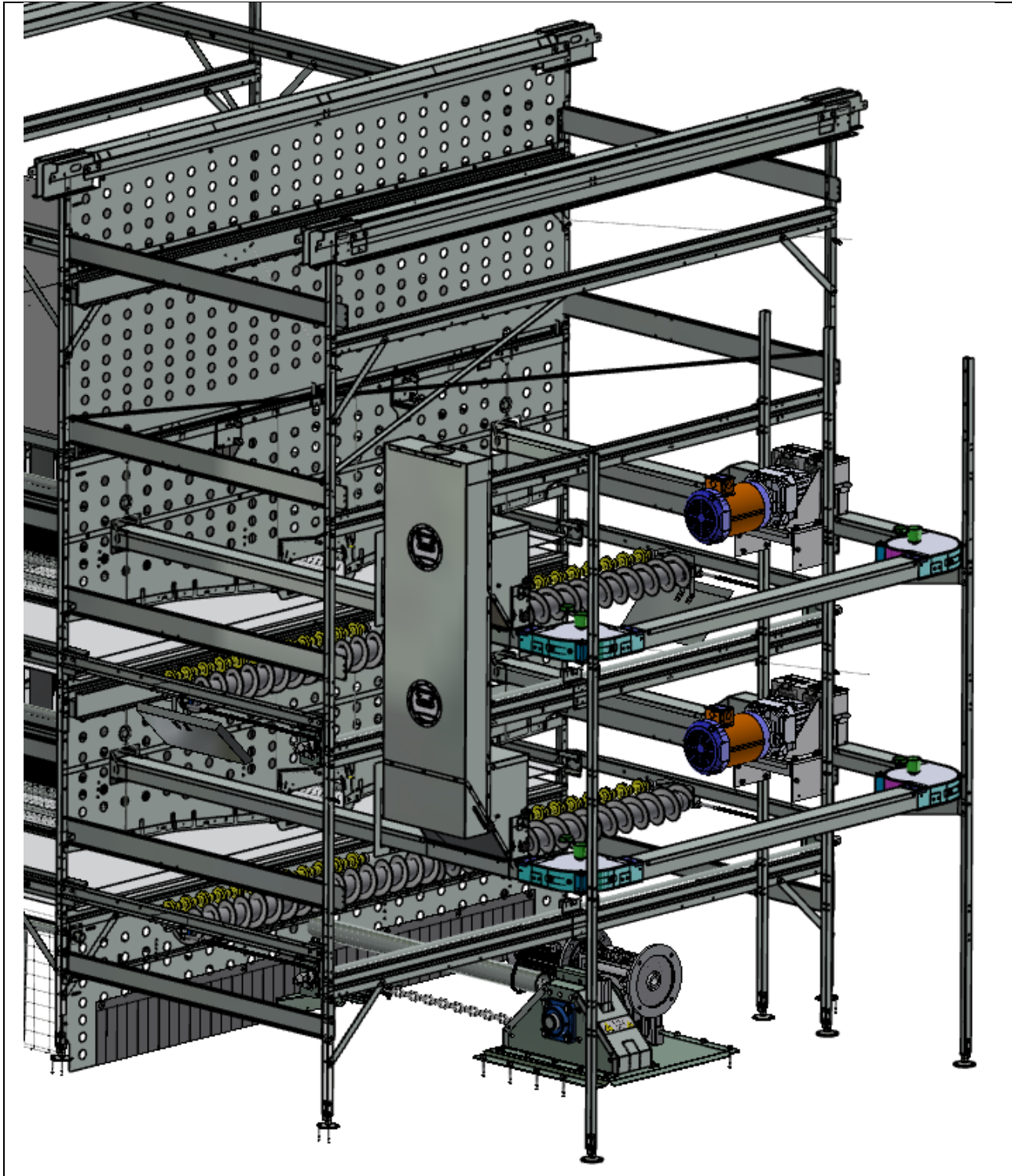

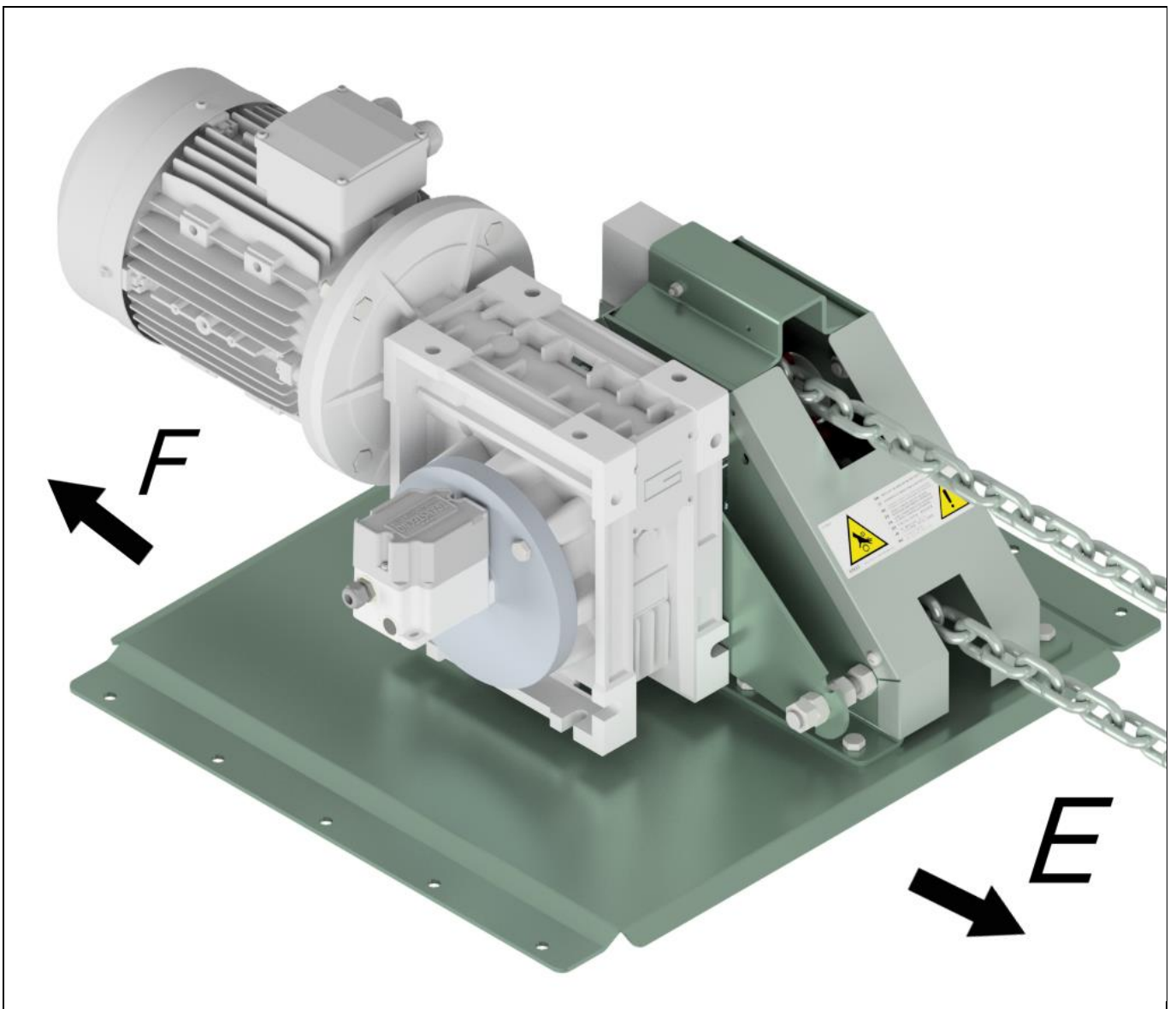

3.2.3.5.1 Mounting U connection

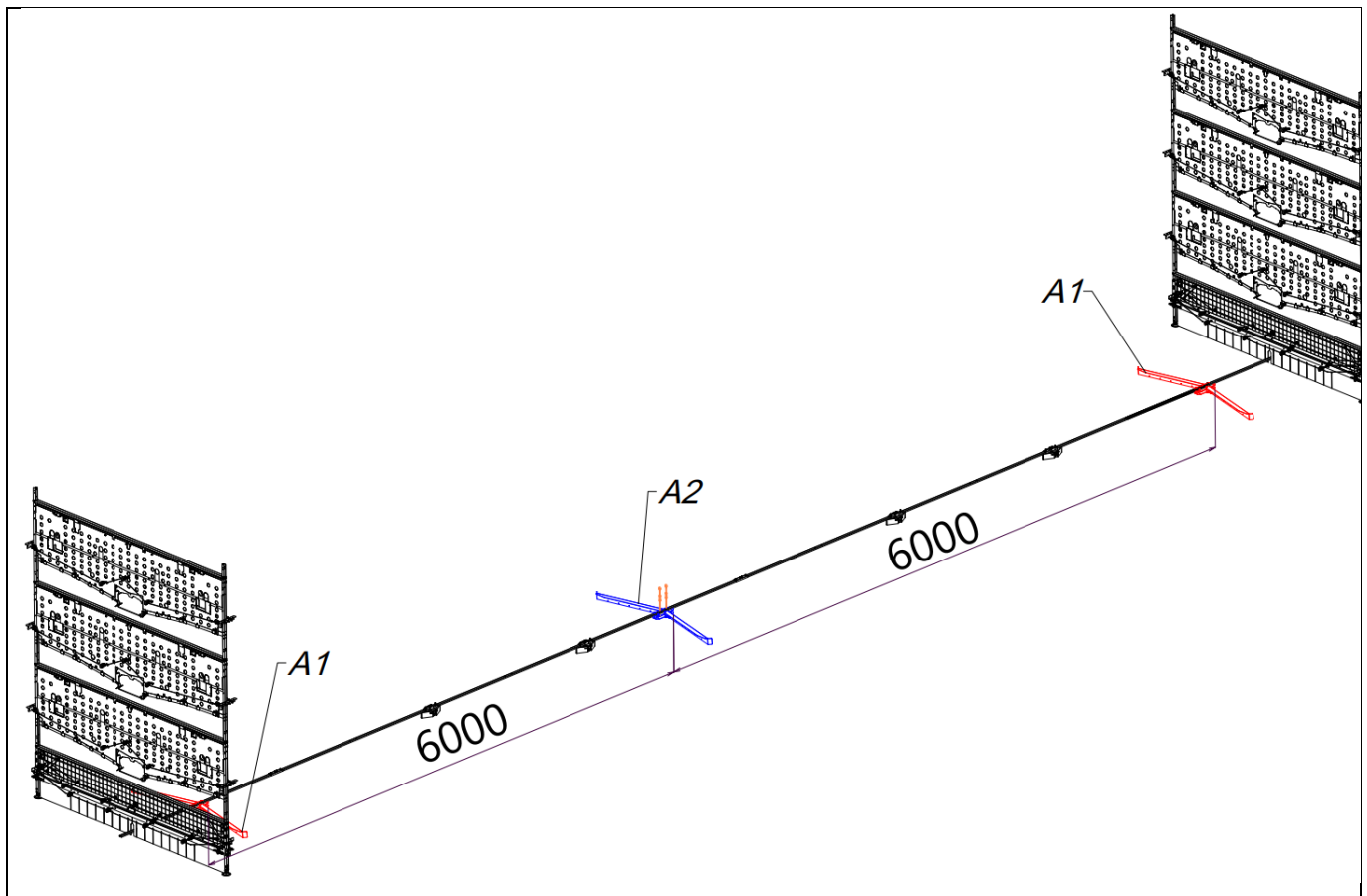

ASSEMBLE ONLY IF THERE IS NECESSARY STROKE BETWEEN TWO SECTOR CLOSURES
CHECK THAT THE SCRAPER WITH THE EYE SCREW DOES NOT PASS BELOW THE CURTAINS. PLACE ONE IN THE MIDDLE OF EACH SECTOR.
BE SURE THAT THE SCRAPER HAS A STROKE OF 8÷10 m

POS.	CODICE	DESCRIZIONE
1	DA00056	NUT M 8 5588 Medium Zn
2	DA48880	SPECIAL NUT M8x13x40
3	OC102446	EYE SCREW DIA 8 Inx
4	RO01917	WASHER DIA 8 x 16 ZN
5	VI28366	BOLT 8 x 150 5739 TF 8.8 Zn

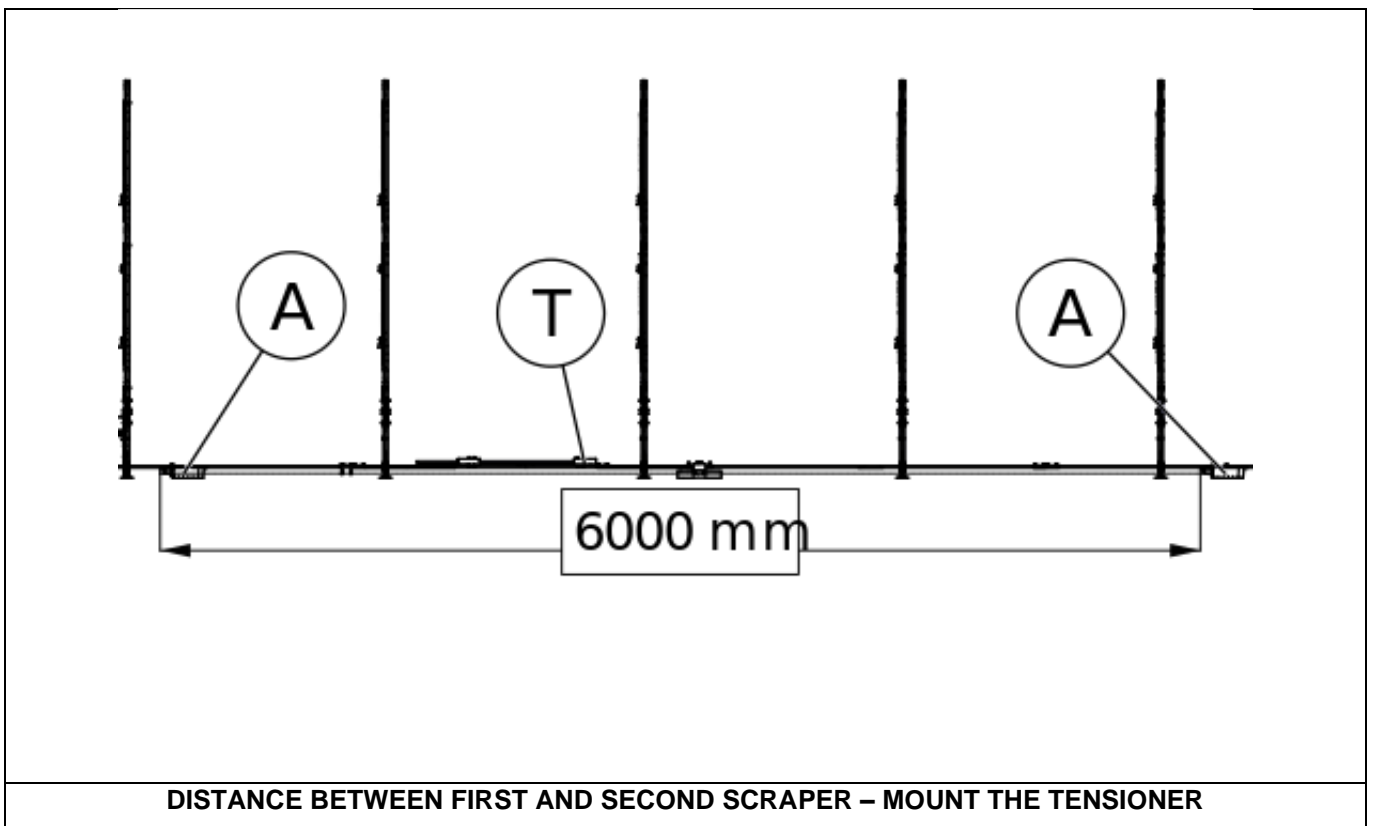

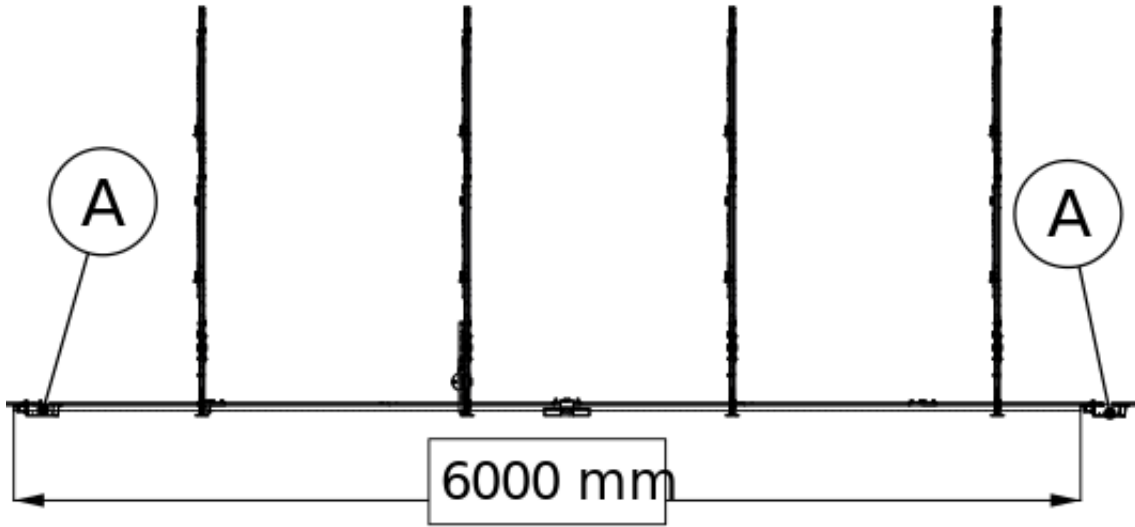

DISTANCE BETWEEN SCRAPERS FROM THE SECOND TO THE LAST SCRAPER (NO PUSH SCRAPER)

3.2.3.6 Tensioner assembly



POSITIONING OF THE TENSIONER BETWEEN THE FIRST AND SECOND SCRAPERS

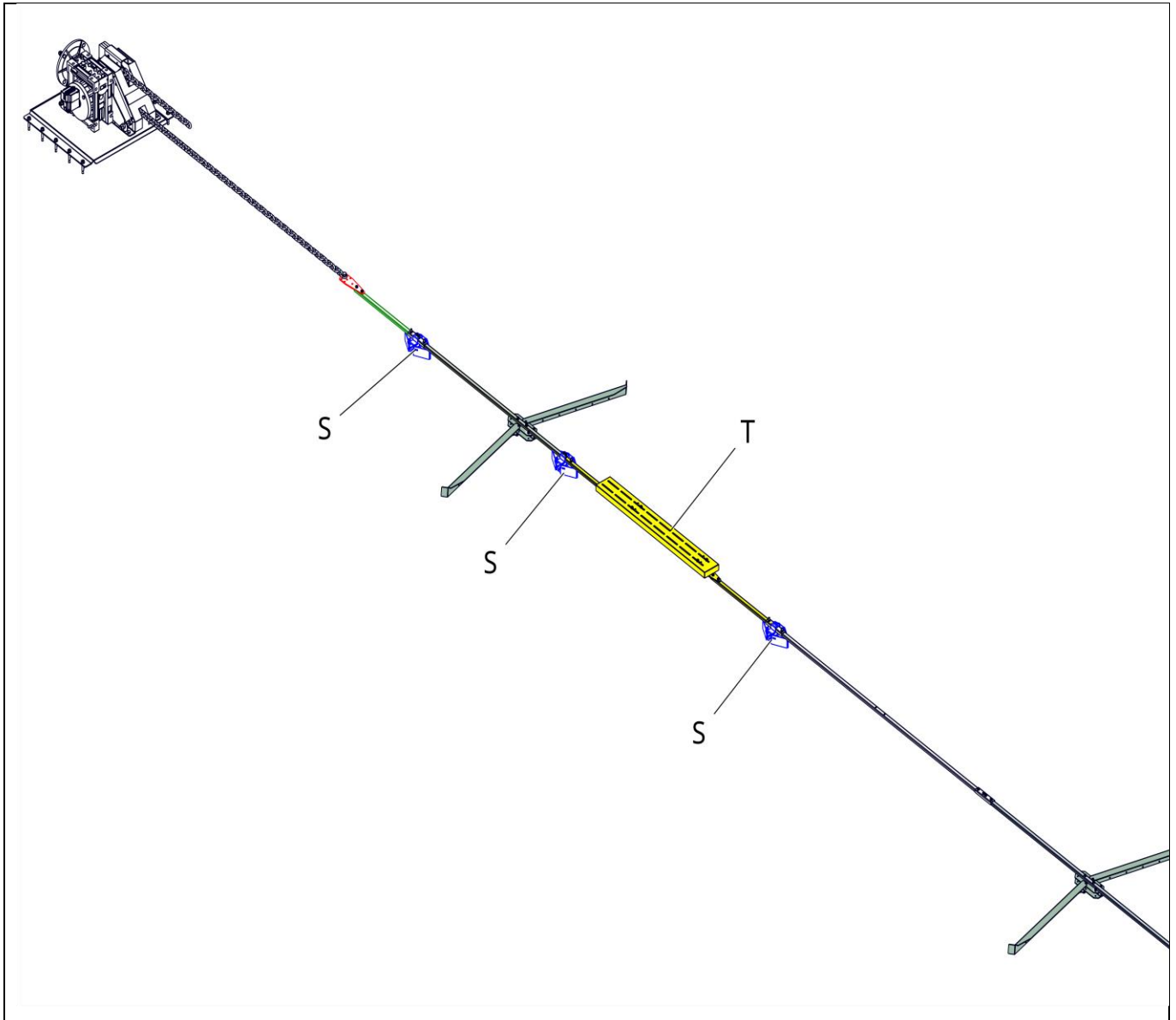



WEB



You Tube

